



INTERNATIONAL APPLICATION PUBLISHED UNDER THE PATENT COOPERATION TREATY (PCT)

(31) International Patent Classification: A61M 15/02, B05B 5/02, A61M 15/00		(11) International Publication Number: WO 94/19042
A1		(43) International Publication Date: 1 September 1994 (19.09.94)
(51) International Application Number: PCT/GB94/00333	(52) Designated States: CA, CH, GB, US, European patent (AT, BE, CH, DE, DK, ES, FR, GR, IT, LI, MC, PL, PT, SE).	
(53) International Filing Date: 21 February 1994 (21.02.94)	Published: With international search report.	
(54) Priority Date: 20 February 1993 (19.02.93)	GB	
(71) Applicant (for all designated States except US): BESPFAK PLC (BESPFAK), Bessan Way, North Lynn Industrial Estate, King's Lynn, Norfolk PE30 2JG (GB).		
(72) Inventors and (73) Inventor/Applicant (for US only): BALACHANDRAN, Whymondra (BACHB); 9 Bessan Road, Gillingham, Bessan Way, North Lynn Industrial Estate, King's Lynn, Norfolk PE30 2JG (GB); ARMAH, Chandray, Bessan Way, North Lynn Industrial Estate, King's Lynn, Norfolk PE30 2JG (GB); BARNES, Paul, Bessan Way, North Lynn Industrial Estate, King's Lynn, Norfolk PE30 2JG (GB).		
(74) Agents: BOULT WADE TERNANT, 27 Piccadilly Street, London W6A 1HQ (GB).		

(54) Title: **INHALATION APPARATUS**

(57) Abstract

A housing defines a passageway having a mouth piece at one end and through which air is inhalable through the passageway, a dispensing means connected to the housing and operable to dispense a metered dose of aerosol liquid or powder. Electrodes (16, 22) are located intermediate the dispensing means and the mouth piece and define a charging region (20). A charging circuit (21) applies a voltage across the electrodes, one of which has a pointed feature, such that particles passing through the charging region acquire charge of a predetermined polarity. A breath sensor (31) is used to co-ordinate operation of the charging circuit with the inhalation of the dose. The site of deposition of inhaled particles within the respiratory tract can thereby be influenced by adjusting the magnitude and polarity of the voltage applied to the electrodes.

**FOR THE PURPOSES OF INFORMATION ONLY**

Codes used to identify States party to the PCT on the first page of pamphlet publishing international applications under the PCT.

AF	Algeria	GB	United Kingdom	MB	Madagascar
AG	Argentina	GE	Georgia	MF	Maldives
AI	Anguilla	GR	Greece	MG	Malawi
AL	Albania	GU	Guam	ML	Malaysia
AM	Armenia	HK	Hong Kong	MM	Myanmar
AN	Antigua and Barbuda	HN	Honduras	MO	Macao
AO	Angola	IE	Ireland	MP	Marshall Islands
AR	Argentina	IL	Israel	MQ	Martinique
AS	Aruba	IN	India	MR	Morocco
AT	Austria	IT	Italy	MS	Montserrat
AU	Australia	JP	Japan	MT	Malta
AW	Aruba	KE	Kenya	MU	Mauritius
AX	Aland Islands	KG	Kyrgyzstan	MX	Mexico
BA	Bosnia and Herzegovina	KR	Republic of Korea	MY	Malaysia
BB	Barbados	LV	Latvia	MC	Monaco
BC	Bahamas	LI	Liechtenstein	MD	Moldova
BD	Bangladesh	LK	Sri Lanka	ME	Montenegro
BE	Belgium	LU	Luxembourg	MG	Madagascar
BF	Burkina Faso	LV	Latvia	MH	Marshall Islands
BG	Bulgaria	LY	Libya	MI	Maldives
BH	Bahrain	MA	Morocco	ML	Malawi
BI	Burundi	MC	Monaco	MM	Myanmar
BJ	Benin	MD	Moldova	MO	Macao
BK	Bhutan	MG	Madagascar	MP	Marshall Islands
BL	Belize	MH	Marshall Islands	MQ	Martinique
BM	Bermuda	MI	Maldives	MR	Morocco
BN	Brunei Darussalam	ML	Malawi	MS	Montserrat
BO	Bolivia	MM	Myanmar	MT	Malta
BQ	Bonaire, Sint Eustatius and Saba	MO	Macao	MU	Mauritius
BR	Brazil	MP	Marshall Islands	MX	Mexico
BS	Bahamas	MQ	Martinique	MY	Malaysia
BT	Bhutan	MR	Morocco	MC	Monaco
BV	Bouvet Island	MS	Montserrat	MD	Moldova
BW	Botswana	MT	Malta	ME	Montenegro
BY	Belarus	MU	Mauritius	MG	Madagascar
BZ	Belize	MX	Mexico	MH	Marshall Islands
CA	Canada	MY	Malaysia	MI	Maldives
		MO	Macao	ML	Malawi
		MP	Marshall Islands	MM	Myanmar
		MQ	Martinique	MO	Macao
		MR	Morocco	MP	Marshall Islands
		MS	Montserrat	MQ	Martinique
		MT	Malta	MR	Morocco
		MU	Mauritius	MS	Montserrat
		MX	Mexico	MT	Malta
		MY	Malaysia	MU	Mauritius
		MC	Monaco	MX	Mexico
		MD	Moldova	MY	Malaysia
		ME	Montenegro	MC	Monaco
		MG	Madagascar	MD	Moldova
		MH	Marshall Islands	ME	Montenegro
		MI	Maldives	MG	Madagascar
		ML	Malawi	MH	Marshall Islands
		MM	Myanmar	MI	Maldives
		MO	Macao	ML	Malawi
		MP	Marshall Islands	MM	Myanmar
		MQ	Martinique	MO	Macao
		MR	Morocco	MP	Marshall Islands
		MS	Montserrat	MQ	Martinique
		MT	Malta	MR	Morocco
		MU	Mauritius	MS	Montserrat
		MX	Mexico	MT	Malta
		MY	Malaysia	MU	Mauritius
		MC	Monaco	MX	Mexico
		MD	Moldova	MY	Malaysia
		ME	Montenegro	MC	Monaco
		MG	Madagascar	MD	Moldova
		MH	Marshall Islands	ME	Montenegro
		MI	Maldives	MG	Madagascar
		ML	Malawi	MH	Marshall Islands
		MM	Myanmar	MI	Maldives
		MO	Macao	ML	Malawi
		MP	Marshall Islands	MM	Myanmar
		MQ	Martinique	MO	Macao
		MR	Morocco	MP	Marshall Islands
		MS	Montserrat	MQ	Martinique
		MT	Malta	MR	Morocco
		MU	Mauritius	MS	Montserrat
		MX	Mexico	MT	Malta
		MY	Malaysia	MU	Mauritius
		MC	Monaco	MX	Mexico
		MD	Moldova	MY	Malaysia
		ME	Montenegro	MC	Monaco
		MG	Madagascar	MD	Moldova
		MH	Marshall Islands	ME	Montenegro
		MI	Maldives	MG	Madagascar
		ML	Malawi	MH	Marshall Islands
		MM	Myanmar	MI	Maldives
		MO	Macao	ML	Malawi
		MP	Marshall Islands	MM	Myanmar
		MQ	Martinique	MO	Macao
		MR	Morocco	MP	Marshall Islands
		MS	Montserrat	MQ	Martinique
		MT	Malta	MR	Morocco
		MU	Mauritius	MS	Montserrat
		MX	Mexico	MT	Malta
		MY	Malaysia	MU	Mauritius
		MC	Monaco	MX	Mexico
		MD	Moldova	MY	Malaysia
		ME	Montenegro	MC	Monaco
		MG	Madagascar	MD	Moldova
		MH	Marshall Islands	ME	Montenegro
		MI	Maldives	MG	Madagascar
		ML	Malawi	MH	Marshall Islands
		MM	Myanmar	MI	Maldives
		MO	Macao	ML	Malawi
		MP	Marshall Islands	MM	Myanmar
		MQ	Martinique	MO	Macao
		MR	Morocco	MP	Marshall Islands
		MS	Montserrat	MQ	Martinique
		MT	Malta	MR	Morocco
		MU	Mauritius	MS	Montserrat
		MX	Mexico	MT	Malta
		MY	Malaysia	MU	Mauritius
		MC	Monaco	MX	Mexico
		MD	Moldova	MY	Malaysia
		ME	Montenegro	MC	Monaco
		MG	Madagascar	MD	Moldova
		MH	Marshall Islands	ME	Montenegro
		MI	Maldives	MG	Madagascar
		ML	Malawi	MH	Marshall Islands
		MM	Myanmar	MI	Maldives
		MO	Macao	ML	Malawi
		MP	Marshall Islands	MM	Myanmar
		MQ	Martinique	MO	Macao
		MR	Morocco	MP	Marshall Islands
		MS	Montserrat	MQ	Martinique
		MT	Malta	MR	Morocco
		MU	Mauritius	MS	Montserrat
		MX	Mexico	MT	Malta
		MY	Malaysia	MU	Mauritius
		MC	Monaco	MX	Mexico
		MD	Moldova	MY	Malaysia
		ME	Montenegro	MC	Monaco
		MG	Madagascar	MD	Moldova
		MH	Marshall Islands	ME	Montenegro
		MI	Maldives	MG	Madagascar
		ML	Malawi	MH	Marshall Islands
		MM	Myanmar	MI	Maldives
		MO	Macao	ML	Malawi
		MP	Marshall Islands	MM	Myanmar
		MQ	Martinique	MO	Macao
		MR	Morocco	MP	Marshall Islands
		MS	Montserrat	MQ	Martinique
		MT	Malta	MR	Morocco
		MU	Mauritius	MS	Montserrat
		MX	Mexico	MT	Malta
		MY	Malaysia	MU	Mauritius
		MC	Monaco	MX	Mexico
		MD	Moldova	MY	Malaysia
		ME	Montenegro	MC	Monaco
		MG	Madagascar	MD	Moldova
		MH	Marshall Islands	ME	Montenegro
		MI	Maldives	MG	Madagascar
		ML	Malawi	MH	Marshall Islands
		MM	Myanmar	MI	Maldives
		MO	Macao	ML	Malawi
		MP	Marshall Islands	MM	Myanmar
		MQ	Martinique	MO	Macao
		MR	Morocco	MP	Marshall Islands
		MS	Montserrat	MQ	Martinique
		MT	Malta	MR	Morocco
		MU	Mauritius	MS	Montserrat
		MX	Mexico	MT	Malta
		MY	Malaysia	MU	Mauritius
		MC	Monaco	MX	Mexico
		MD	Moldova	MY	Malaysia
		ME	Montenegro	MC	Monaco
		MG	Madagascar	MD	Moldova
		MH	Marshall Islands	ME	Montenegro
		MI	Maldives	MG	Madagascar
		ML	Malawi	MH	Marshall Islands
		MM	Myanmar	MI	Maldives
		MO	Macao	ML	Malawi
		MP	Marshall Islands	MM	Myanmar
		MQ	Martinique	MO	Macao
		MR	Morocco	MP	Marshall Islands
		MS	Montserrat	MQ	Martinique
		MT	Malta	MR	Morocco
		MU	Mauritius	MS	Montserrat
		MX	Mexico	MT	Malta
		MY	Malaysia	MU	Mauritius
		MC	Monaco	MX	Mexico
		MD	Moldova	MY	Malaysia
		ME	Montenegro	MC	Monaco
		MG	Madagascar	MD	Moldova
		MH	Marshall Islands	ME	Montenegro
		MI	Maldives	MG	Madagascar
		ML	Malawi	MH	Marshall Islands
		MM	Myanmar	MI	Maldives
		MO	Macao	ML	Malawi
		MP	Marshall Islands	MM	Myanmar
		MQ	Martinique	MO	Macao
		MR	Morocco	MP	Marshall Islands
		MS	Montserrat	MQ	Martinique
		MT	Malta	MR	Morocco
		MU	Mauritius	MS	Montserrat
		MX	Mexico	MT	Malta
		MY	Malaysia	MU	Mauritius
		MC	Monaco	MX	Mexico
		MD	Moldova	MY	Malaysia
		ME	Montenegro	MC	Monaco
		MG	Madagascar	MD	Moldova
		MH	Marshall Islands	ME	Montenegro
		MI	Maldives	MG	Madagascar
		ML	Malawi	MH	Marshall Islands
		MM	Myanmar	MI	Maldives
		MO	Macao	ML	Malawi
		MP	Marshall Islands	MM	Myanmar
		MQ	Martinique	MO	Macao
		MR	Morocco	MP	Marshall Islands
		MS	Montserrat	MQ	Martinique
		MT	Malta	MR	Morocco
		MU	Mauritius	MS	Montserrat
		MX	Mexico	MT	Malta
		MY	Malaysia	MU	Mauritius
		MC	Monaco	MX	Mexico
		MD	Moldova	MY	Malaysia
		ME	Montenegro	MC	Monaco
		MG	Madagascar	MD	Moldova
		MH	Marshall Islands	ME	Montenegro
		MI	Maldives	MG	Madagascar
		ML	Malawi	MH	Marshall Islands
		MM	Myanmar	MI	Maldives
		MO	Macao	ML	Malawi
		MP	Marshall Islands	MM	Myanmar
		MQ	Martinique	MO	Macao
		MR	Morocco	MP	Marshall Islands
		MS	Montserrat	MQ	Martinique
		MT	Malta	MR	Morocco
		MU	Mauritius	MS	Montserrat
		MX	Mexico	MT	Malta
		MY	Malaysia	MU	Mauritius
		MC	Monaco	MX	Mexico
		MD	Moldova	MY	Malaysia
		ME	Montenegro	MC	Monaco
		MG	Madagascar	MD	Moldova
		MH	Marshall Islands	ME	Montenegro
		MI	Maldives	MG	Madagascar
		ML	Malawi	MH	Marshall Islands
		MM	Myanmar	MI	Maldives
		MO	Macao	ML	Malawi
		MP	Marshall Islands	MM	Myanmar
		MQ	Martinique	MO	Macao
		MR	Morocco	MP	Marshall Islands
		MS	Montserrat	MQ	Martinique
		MT	Malta	MR	Morocco
		MU	Mauritius	MS	Montserrat
		MX	Mexico	MT	Malta
		MY</			

Such an arrangement of electrodes results in ionised field charging of particles passing through the charging region. Corona discharge in the vicinity of the high curvature pointed feature of the first electrode results in formation of ions of both polarities, those ions having the same polarity as the first electrode being confined by electrostatic attraction to the immediate vicinity of the first electrode and the ions of opposite polarity tending to migrate towards the second electrode. The migrating ions are hence unipolar and the particles colliding with such ions will acquire electrostatic charge of the same polarity as those ions i.e. the predetermined polarity of the first electrode.

The first electrode may comprise a setaceous electrode having a multitude of points.

Conveniently the first electrode may comprise a carbon fibre brush.

Conveniently one or other of the electrodes is centrally located with respect to the passageway and the other of the electrodes being peripherally located with respect to the passageway whereby a radial migration of ions is established in use between the electrodes such that a region traversed by the migrating ions constitutes the charging region.

The first electrode may be peripherally located and may constitute a setaceous electrode.

The charging circuit may comprise a voltage control circuit operable to control the voltage applied between the electrodes to a predetermined level associated with a required mean level of charge to be imparted in use to the particles.

Typically the voltage will lie in the range 1 to 10 kvolts and will be selected according to the electrode geometry and spacing.

Conveniently the charging circuit comprises a

timing circuit operable to apply the voltage between the electrodes for a predetermined time interval in response to an actuating signal.

The predetermined time interval is selected to be greater than the time taken for the inhalable substance to be dispensed from the dispensing means into the passageway and for subsequent inhalation to be completed.

The housing, the charging means and the mouthpiece may if required together constitute an adaptor releasably connectible to the dispensing means.

The apparatus may include a breath sensor mounted in the passageway for sensing the inhalation of breath through the passageway and operatively connected to the charging circuit whereby the charging circuit is activated and the voltage is applied to the electrodes in response to inhalation being sensed.

The period during which the charging circuit is energised may thereby be kept to a minimum in order to conserve power, this being particularly important where the apparatus is a hand held device including an integral power supply.

The dispenser may comprise an electrically operated actuating means which is operatively connected to the breath sensor whereby in use the dispenser is actuated to dispense a dose of the substance in response to inhalation being sensed.

This is particularly important when administering a substance intended to be deposited deep within the lungs of a patient. Under these conditions it is important that the dispensed dose is discharged so as to be inhaled at the beginning of the breath cycle, the typical time during which discharge proceeds being 0.1 to 0.3 seconds for a

metered dose inhaler of the pressurised dispenser type. If the dose is released early during inspiration then the probability of the particles reaching the alveolar regions is increased whereas if the release of the dose is during the latter part of the cycle, the particles will tend to be deposited predominantly in the upper airways with much of the dose being lost during exhalation. The additional benefit of modifying the charge associated with the particles provides an additional means of targeting a particular region of the lung. For particles of a given size and type, the preferred net charge per particle can be determined by empirical or modelling techniques and the magnitude and polarity of voltage applied to the electrodes of the apparatus may thereby be adjusted accordingly.

The use of the apparatus thereby enables the substance to be administered in a localised manner with minimal loss from exhalation.

Conveniently the breath sensor comprises a membrane of piezoelectric material supported relative to the housing by a support arranged such that the membrane flexes in response to a change of air pressure in the passageway and thereby generates a signal representative of inhalation being sensed.

Such membrane sensors are known from GB-A-2266466.

The apparatus may comprise a dispenser which is mechanically actuable by displacement of an actuating member relative to the housing and may comprise a displacement sensor operatively connected to the charging circuit and responsive to displacement of the actuating member whereby the charging circuit is actuated and the voltage is applied to the electrodes in response to displacement being sensed.

Synchronisation between the dispensing of the dose and the charging of the electrodes may thereby be achieved in a straightforward manner.

Conveniently where the dispenser comprises a pressurised dispensing container having a dispensing valve stem and a metering valve actuated by relative movement between the valve stem and the container, the container may constitute the actuating member and the displacement sensor may comprise a switch responsive to movement of the container relative to the housing.

The charging circuit may comprise a timing circuit operable to apply the voltage between the electrodes for a predetermined time interval.

This is particularly useful when used in conjunction with a breath sensor of the piezoelectric type where the sensor generates an electrical impulse in response to a change of pressure at the beginning of inhalation rather than a sustained pulse throughout the duration of inhalation.

The dispensing means may be operable to dispense particles in the form of liquid droplets or alternatively in the form of a powder.

Preferably the apparatus comprises power supply means provided integrally with the housing whereby the apparatus is self-contained and hand holdable.

Preferred embodiments of the present invention will now be described by way of example only and with reference to the accompanying drawings of which:-

Figure 1 is a part-sectioned side elevation of a first embodiment of apparatus in accordance with the present invention and having a pointed central electrode;

Figure 2 is a part-sectioned side elevation of the second embodiment having a low curvature central electrode and a setaceous outer electrode.

Figure 3 is an exploded perspective view of a third embodiment comprising an adaptor releasably connectable to a dispensing means.

Figure 4 is a part sectioned side elevation of a fourth embodiment which includes a breath sensor and an electrically operated dispenser,

Figure 5 is a part sectioned side elevation of a fifth embodiment having a breath sensor and an alternative electrically operated dispenser,

Figure 6 is a schematic diagram showing the operation of a mechanically actuated dispenser with a displacement sensor,

Figure 7 is a schematic diagram showing the operation of an apparatus including an actuation sensing switch and a timer, and

Figure 8 is a schematic diagram illustrating the operation of an apparatus having a breath sensor and a control circuit including a timer.

A first apparatus shown in Figure 1 comprises a housing 2 having a socket portion 3 defining a cylindrical socket 4 in which is slidably received a pressurised dispensing container 5. The pressurised dispensing container 5 has a tubular valve stem 6 through which a metered dose of a liquid droplet aerosol is dispensed when the container is moved relative to the stem, the stem being fixedly received in an actuator 7 defining a nozzle 8 through which the aerosol is directed.

The housing 2 further comprises a tubular mouthpiece 9 defining a passageway 10 communicating at one end with an inhalation port 11 and at its other end with air inlet openings 12 admitting air to the passageway from the socket 4.

A frusto-conical baffle 13 is located within the passageway 10 such that a first end 14 of small diameter is presented to the nozzle 8 and a second

end 15 of larger diameter extends towards the inhalation port 11 such that aerosol particles propelled from the nozzle 8 are able to pass freely through the baffle 13 and emerge from the inhalation port 11.

A first electrode 16 is mounted in the baffle 13 and includes a pointed feature 17 extending axially within the baffle in a direction towards the inhalation port 11. The pointed feature 17 is integrally formed with a transversely extending support arm 18, the support arm and pointed feature being formed of metal sheet and electrically connected by means of a wire 19 to a first terminal 20 of a charging circuit 21.

A second electrode 22 which is annular end of smooth configuration is mounted in the baffle 13 at a location intermediate the support arm 18 and the inhalation port 11 such that the pointed feature 17 extends centrally through and at right angles to the second electrode 22.

The second electrode 22 is connected by a second wire 23 to a second terminal 24 of the charging circuit 21.

The charging circuit 21 together with a power supply battery (not shown) is housed within a further compartment 25 defined by the housing 3.

In use the charging circuit 21 is energised and migrating ions between the first electrode 16 and the second electrode 22 define a charging region indicated schematically by broken lines 26, the charging region being traversed by migrating ions having the same polarity as the first electrode.

The pressurised dispensing container 5 is manually depressed relative to the actuator 7 thereby discharging a metered dose of a liquid droplet aerosol from the nozzle 8. The droplets are

propelled towards the inhalation port 11 via the baffle 13 and through the passageway 10 and are thereby constrained to pass through the charging region 26.

At the same time as actuating the pressurised dispensing container 5 the user inhales through the inhalation port 11 and the aerosol droplets are thereby administered to the respiratory tract of the user.

The droplets emerging from the nozzle 8 will carry an inherent level of electrostatic charge which is characteristic of the particular dispenser and will typically depend upon the nature of the propellant fluid, the structure of the valve and the materials with which the liquid comes into contact in being dispensed. The mean level of inherent charge can be measured by known techniques and compared with the optimum level of electrostatic charge required to target a particular site in the respiratory tract, this required level of charge being determined by known methods such as mathematical modelling and clinical trials.

The required level of voltage supplied between the first and second electrodes 16 and 22 can be empirically determined by measuring the mean level of electrostatic charge of particles emerging from the inhalation port and adjusting the voltage until the charge level matches the required level to achieve satisfactory deposition at the selected site.

A second apparatus will now be described with reference to Figure 2 using corresponding reference numerals to those of Figure 1 where appropriate for corresponding elements.

The second apparatus 30 also includes a pressurised dispenser container 5 arranged to deliver an aerosol spray of liquid droplets from a nozzle 8

when the container is depressed within a socket 4 of a housing 3.

A passageway 10 communicates with the socket 4 and with an inhalation port 11 arranged such that when a user inhales through the port 11 air is drawn through the passageway 10 from the socket 4.

The passageway 10 is cylindrical and has an internal cylindrical surface 31 to which is fixed an annular first electrode 16 formed of a setaceous material having a multitude of electrically conductive metallic points 32.

Axially disposed within the passageway is a second electrode 22 formed as a flat strip of metal plate formed integrally with a diametrically extending support arm 18.

A forward end portion 33 of the second electrode 22 has a smoothly rounded tip 34 located centrally within the first electrode 16.

The first and second electrodes 16 and 22 are connected to a charging circuit 21 via respective wires 19 and 23.

In use the charging circuit 21 is energised to apply a d.c. voltage between the first and second electrodes such that corona discharge in the air surrounding the points 32 results in migration of ions having the same polarity as the first electrode in a generally radial pattern towards the second electrode 22.

The migrating ions define a charging region indicated generally by broken lines 26 through which aerosol liquid droplets emerging from nozzle 8 are propelled in use prior to being inhaled from the inhalation port 11.

A further alternative apparatus 40 is shown in Figure 3 in which corresponding reference numerals to those of Figure 2 are used where appropriate for

corresponding elements.

The apparatus 40 is shown in exploded view in which an adaptor 41 is ready to be presented to a dispenser 42 such that a tubular member 43 defining an outlet duct 44 of the dispenser 42 is receivable as a sliding fit within a second tubular member 45 of the adaptor 41 so that when assembled the tubular members 43 and 45 together define a passageway 10.

The dispenser 42 is operable to dispense air-borne particles through the passageway 10 when actuated.

The adaptor 41 contains first and second electrodes 16 and 22 corresponding to those described with reference to Figure 2 and are connected by wires 19 and 23 to a charging circuit 21 located within a circuit housing 46 formed integrally with the second tubular member 45.

The charging circuit 21 contains its own power supply and is thereby self-contained. The adaptor 41 can therefore be disconnected from the dispenser 42 and fitted with a replacement dispenser when required.

The dispenser 42 is in this example a powder dispenser operable to dispense a metered dose of powdered medicament which is air-borne on inhaled air. A mouthpiece 9 formed integrally with the second tubular member 45 defines an inhalation port 11 through which air is inhaled in use, the inhaled air being drawn through the tubular member 43 from the dispenser 42 so that when actuated the dispenser delivers air-borne particles to the user. The first and second electrodes 16 and 22 are energised during inhalation so as to create a charging region corresponding to the charging region 16 shown in Figure 2 and by means of which a predetermined level of charge is imparted to the particles prior to inhalation.

The dispenser 42 may alternatively be a liquid aerosol dispenser such as the pressurised dispenser container 5 of Figures 1 and 2.

The setaceous material constituting the electrode 16 of Figures 2 and 3 may alternatively be formed by a carbon fibre brush.

Further alternative apparatus will now be described with reference to Figures 4 to 6 using corresponding reference numerals to those of preceding Figures where appropriate for corresponding elements.

In Figure 4 a fourth apparatus 50 is similar to the apparatus 1 of Figure 1 but includes an elongated mouth piece 9 which, in addition to the electrodes 16 and 22, accommodates a breath sensor 51.

The breath sensor 51 consists of a piezoelectric membrane 52 which is held by a support member 53 so as to normally lie in contact with a side wall of the mouth piece 9. The support member 53 is generally tubular in shape and fits snugly within the mouth piece 9. The support member 53 is provided with cut outs such as the cut out 54 visible in Figure 4 through which respective unclamped portions of the membrane 52 are exposed, each exposed portion of the membrane being surrounded by an annular clamped portion which is overlaid by the support member and thereby clamped in contact with the side wall of the mouth piece.

The membrane 52 is a film of PVDF (polyvinylidene fluoride) material upon which are formed sensor electrodes in a known manner to provide an electrical up signal responsive to flexure of the film.

An output lead 55 connects the membrane to an electrically operated valve 56 which is arranged to dispense a metered dose of fluid from a pressurised

dispensing container 5 in response to a signal being received from the breath sensor 51.

The breath sensor 51 is also connected by output leads 57 to terminals 58 of the charging circuit 21 which is configured so as to generate a voltage applied to the electrodes only in response to a signal received from the breath sensor. The charging circuit 21 also includes a timer programmed to measure a predetermined time interval during which the voltage is maintained before deactivating the circuit. In this way, the charging circuit 21 is energised only when required i.e. during inhalation as sensed by the breath sensor 51.

The electrically operated valve 56 is similarly arranged to be actuated in response to inhalation being sensed by the breath sensor 51. The piezoelectric membrane 52 will flex at the initiation of inhalation, at which time there is a pronounced pressure change within the passageway, with the result that actuation of the valve 56 occurs at the initial stages of inhalation. This is particularly advantageous when it is required for the dose to be delivered deep into the lungs of the patient who is inhaling. The valve 56 will typically be opened during a period which is very short compared with the length of time taken for a single breath to be taken, a typical time being in the range 0.1 to 0.3 seconds during which time the dose is progressively dispensed into the passageway.

Figure 5 illustrates a fifth apparatus 60 which includes a first electrode 16 formed of setaceous material 32 in a manner similar to that described with reference to Figure 2. The apparatus 60 also includes a breath sensor 51 of the type described with reference to Figure 4 and similarly connected to the charging circuit 21. The sensor 51 is also

connected to an electrically operated actuator 61 arranged to longitudinally displace a pressurised dispensing container 5 relative to its associated valve stem 6 such that, on receipt of an actuating signal from the sensor 51, the actuator 61 displaces the container 5 thereby actuating a metering valve 62. The discharge of a metered dose of fluid in the form of droplets or powder can thereby be timed to coincide with the initiation of inhalation as sensed by the breath sensor 51.

The dose is dispersed within the passageway so as to be entrained in the inhaled air and passes through a charging region 26 where the charge carried by the airborne particles is modified in a predetermined manner prior to inhalation.

Figure 6 illustrates schematically a sixth apparatus 71 in which a pressurised dispensing container is manually actuated by relative movement between the container and a fixed actuator 7 defining a nozzle 8, there being provided a mechanical switch 72 arranged to sense displacement of the container 5 relative to the housing 6 to which the switch is mounted. The switch 72 is connected to the charging circuit and arranged to actuate the circuit whenever the container 5 is displaced. In this way the application of voltage to the electrodes 16, 22 is synchronised with the dispensing action so that the charging region 26 is established simultaneously with the dispersal of the dose into the passageway.

As illustrated schematically in Figure 7, this arrangement may be modified by including a timer in the charging circuit 21, the timer being arranged to prolong the activation of the charging circuit for a predetermined time interval which is greater than the period required for inhalation of the dose. During storage and between actuations of the apparatus in

use, the charging circuit is thereby deactivated thereby prolonging the working life of battery 73 used to power the charging circuit.

Figure 6 illustrates schematically a further arrangement particularly suitable for use with breath sensors of the PVDF type as described with reference to Figure 4 and 5 and where the sensor generates a voltage pulse by piezoelectric action. A control circuit 74 is connected to the breath sensor and arranged to detect any such voltage pulse. The control circuit is arranged to discriminate between piezoelectrically generated pulses of different polarity so as to respond only to inhalation and not to exhalation effects on the membrane.

The control circuit may be used simply to actuate the charging circuit or optionally, as described above with reference to the embodiments of Figures 4 and 5, may be used to also actuate an electrically operable actuator 56 or 61 respectively.

The control circuit will typically include a timer arranged to extend actuation of the charging circuit for a predetermined period.

## CLAIMS:

1. Apparatus (1,30,40,50,60,71) for dispensing an inhalable substance comprising a housing (2) defining a passageway (10), the housing having a mouth piece (9) defining an inhalation port (11) at one end of the passageway and through which a flow of air from the passageway is inhalable in use, a dispensing means (5) connected to the housing and operable to dispense the substance into the passageway at a dispensing location (8) in the form of inhalable particles and charging means (21,16,22) defining a charging region (26) of the passageway located intermediate the inhalation port and the dispensing location the charging means comprising a first electrode (16) having at least one pointed feature (17,32) having a relatively high curvature and located in the passageway, a second electrode (22) having co-operating features of relatively low curvature and located in the passageway and a charging circuit (21) operable to apply a predetermined voltage between the electrodes such that a predetermined polarity is applied to the first electrode whereby the charging means is operable to impart electrostatic charge of predetermined polarity to the particles passing through the charging region, and wherein the dispensing means comprises a metered dose dispenser (5) operable to dispense a metered dose of the substance.

2. Apparatus as claimed in claim 1 wherein the first electrode is a setaceous electrode having a multitude of points (32).

3. Apparatus as claimed in claim 2 wherein the first electrode comprises a carbon fibre brush.

4. Apparatus as claimed in claim 1 wherein one or other of the electrodes is centrally located with respect to the passageway and the other of the electrodes is peripherally located with respect to the passageway whereby a radial migration of ions is established in use between the electrodes such that a region traversed by the migrating ions constitutes the charging region.

5. Apparatus as claimed in claim 4 wherein the first electrode is peripherally located and constitutes a setaceous electrode.

6. Apparatus as claimed in any preceding claim wherein the charging circuit is operable to control the voltage applied between the electrodes to a predetermined level associated with a required mean level of charge to be imparted in use to the particles.

7. Apparatus as claimed in claim 6 wherein the voltage is in the range 1 to 10 kvolts.

8. Apparatus as claimed in any preceding claim comprising a breath sensor (51) mounted in the passageway for sensing the inhalation of breath through the passageway and operatively connected to the charging circuit whereby the charging circuit is activated and the voltage is applied to the electrodes in response to inhalation being sensed.

9. Apparatus as claimed in claim 8 wherein the dispenser comprises electrically operated actuating means (56,61) operatively connected to the sensor whereby in use the dispenser is actuated to dispense a dose of the substance in response to

inhalation being sensed.

10. Apparatus as claimed in any of claims 8 and 9 wherein the breath sensor comprises a membrane (52) of piezoelectric material supported relative to the housing by a support (53) arranged such that the membrane flexes in response to a change of air pressure in the passageway and thereby generate a signal representative of inhalation being sensed.

11. Apparatus as claimed in any of claims 1 to 10 wherein the dispenser is mechanically actuable by displacement of an actuating member (5) relative to the housing and comprising a displacement sensor (72) operatively connected to the charging circuit and responsive to displacement of the actuating member whereby the charging circuit is actuated and the voltage is applied to electrodes in response to displacement being sensed.

12. Apparatus as claimed in claim 11 wherein the dispenser comprises a pressurised dispensing container (5) having a dispensing valve stem (6) and a metering valve (62) actuated by relative movement between the valve stem and the container, wherein the container constitutes the actuating member and the displacement sensor comprises a switch responsive to movement of the container relative to the housing.

13. Apparatus as claimed in any of claims 8 to 12 wherein the charging circuit comprises a timing circuit operable to apply the voltage between the electrodes for a predetermined time interval.

14. Apparatus as claimed in any preceding claim wherein the housing, the charging means and the

nouthpiece together constitute an adaptor (41) releasably connectible to the dispenser.

15. Apparatus as claimed in any preceding claim wherein the dispenser is operable to dispense particles in the form of liquid droplets.

16. Apparatus as claimed in any of claims 1 to 9 wherein the dispenser is operable to dispense particles in the form of a powder.

17. Apparatus as claimed in any preceding claim further comprising power supply means (73) provided integrally with the housing whereby the apparatus is self-contained and hand holdable.

20

25

30

35

FIG. 1.

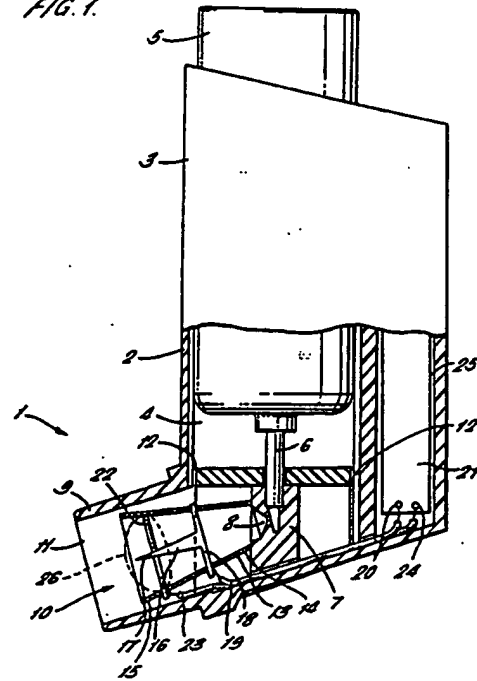
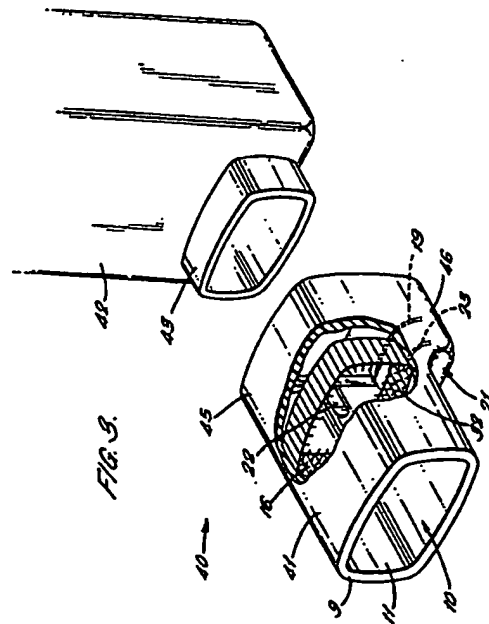
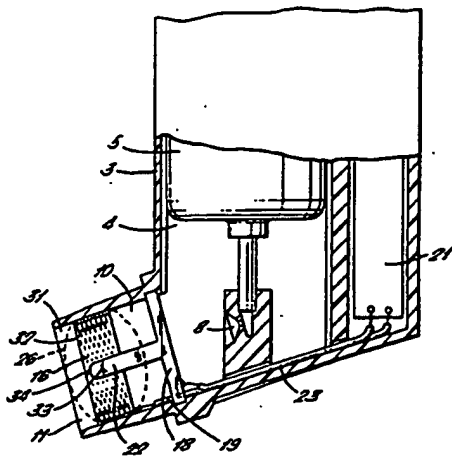
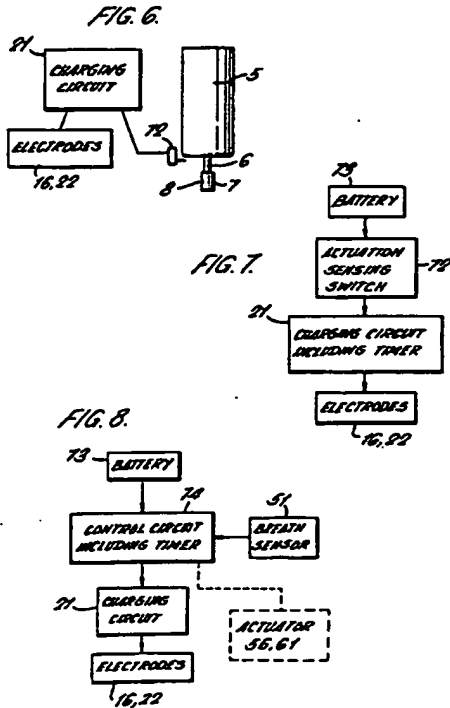
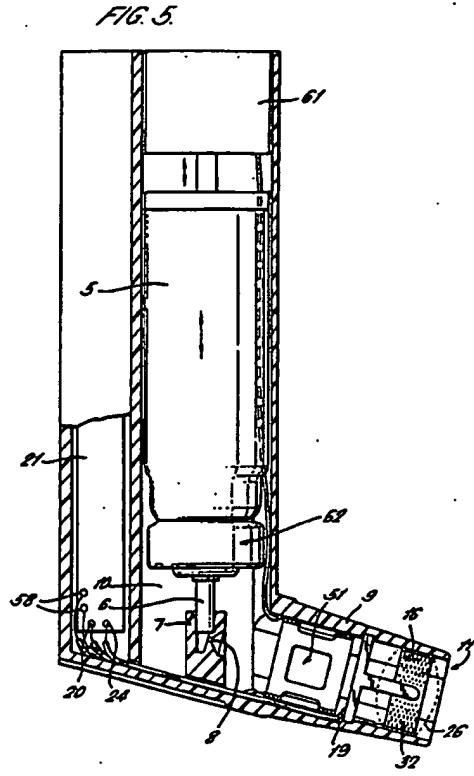
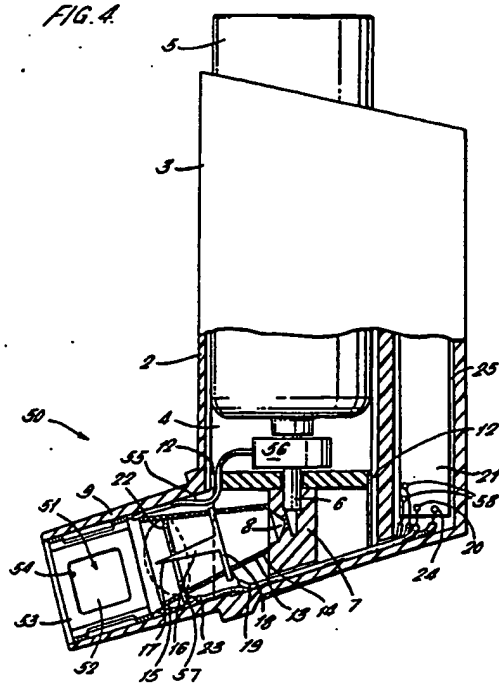

FIG. 2.





INTERNATIONAL SEARCH REPORT		Number of Applications To
		PCT/GB 94/00338
<b>A. CLASSIFICATION OF SUBJECT MATTER</b> IPC 5 AS1M15/02 B05B5/053 AS1M15/00		
According to International Patent Classification (IPC) or to both national classifications and IPC		
<b>B. FIELDS SEARCHED</b> Multilingual descriptions searched (Indicate the system followed by classification symbols) IPC 5 AS1M B05B		
Descriptions searched other than multilingual descriptions to the extent that such descriptions are included in the fields searched		
Documents cited have been examined during the international search phase of this procedure, where pertinent, search report cited		
<b>C. DOCUMENTS CONSIDERED TO BE RELEVANT</b>		
Category*	Character of document, with indication, where appropriate, of the relevant passages	Relevant to claim No.
Y	GB,A,1 045 883 (KERR) 17 April 1963 see the whole document	1,6-12, 15
Y,P	GB,A,2 266 466 (BESPAK PLC) 3 November 1993 cited in the application see page 4, line 19 - page 5, line 38; claims; figures	1,6-12, 15
A'	EP,A,0 448 204 (DESSERTINE) 25 September 1991 see abstract; figures	1,11
A	FR,A,2 605 249 (GAUCHARD) 22 April 1988 see page 5, paragraph 2	2
-/-		
* Further documents are listed in the explanation of this C.		† Prior art documents are listed in open.
* Special categories of cited documents: *A* document defining the general state of the art which is not considered to be of particular relevance *B* earlier document not published as of the international filing date *C* document which may have led to the present invention or which is cited to establish the priority date of another invention or other special cases (see general) *D* document relating to an oral disclosure, the exhibition or other means *E* document published prior to the international filing date but later than the priority date claimed		
† Date of earliest publication of the international filing date or priority date and not to be confused with the application file date to determine the principle of priority belonging to the claim. ‡ Document of particular relevance, the document containing claims to be examined and/or to be considered in connection with the international search. § Document of particular relevance, the document containing claims to be examined in connection with the international search report, each document being referred to a priority claim in the application. ¶ Document of the same priority family.		
Date of the cited acquisition of the international search report 2 May 1994		Date of mailing of the international search report 16.05.94
Place and mailing address of the ISA International Patent Office, P.O. Box 683, Postoffice 2 CH-7030 Yvertois Tel. (+41 26) 766 100, Fax (+41 26) 766 104 Telex (+41 26) 766 100		Applicant's attorney Villeneuve, J-N

C/C (Continuation) DOCUMENTS CONSIDERED TO BE RELEVANT		
Category	Citation of document, with abstract, where appropriate, of the relevant passages	Referent to class. No.
A	US,A,4 971 257 (BIRGE) 20 November 1990 see abstract; figures	1,11,15, 17
A	WO,A,90 03224 (BATTELLE MEMORIAL INSTITUTE) 5 April 1990 see page 3, line 3 - line 8; claims	1
A	US,A,4 228 961 (ITOH) 21 October 1980 see abstract; figures 1,10	4

Form PCT/GA/99 (preparation of national phase) (July 1992)

Patent document cited in search report	Publication date	Patent family member(s)	Publication date
GB-A-1045883		NONE	
GB-A-2266466	03-11-93	NONE	
EP-A-0448204	25-09-91	US-A- 5020527	04-06-91
FR-A-2605249	22-04-88	NONE	
US-A-4971257	20-11-90	NONE	
WO-A-9003224	05-04-90	US-A- 5115971 AU-B- 635902 AU-A- 4302589 DE-D- 68912133 DE-T- 68912133 EP-A- 0435921 JP-T- 4500926	26-05-92 08-04-93 18-04-90 17-02-94 28-04-94 10-07-91 20-02-92
US-A-4228961	21-10-80	NONE	

Form PCT/GA/99 (patent family search) (July 1992)